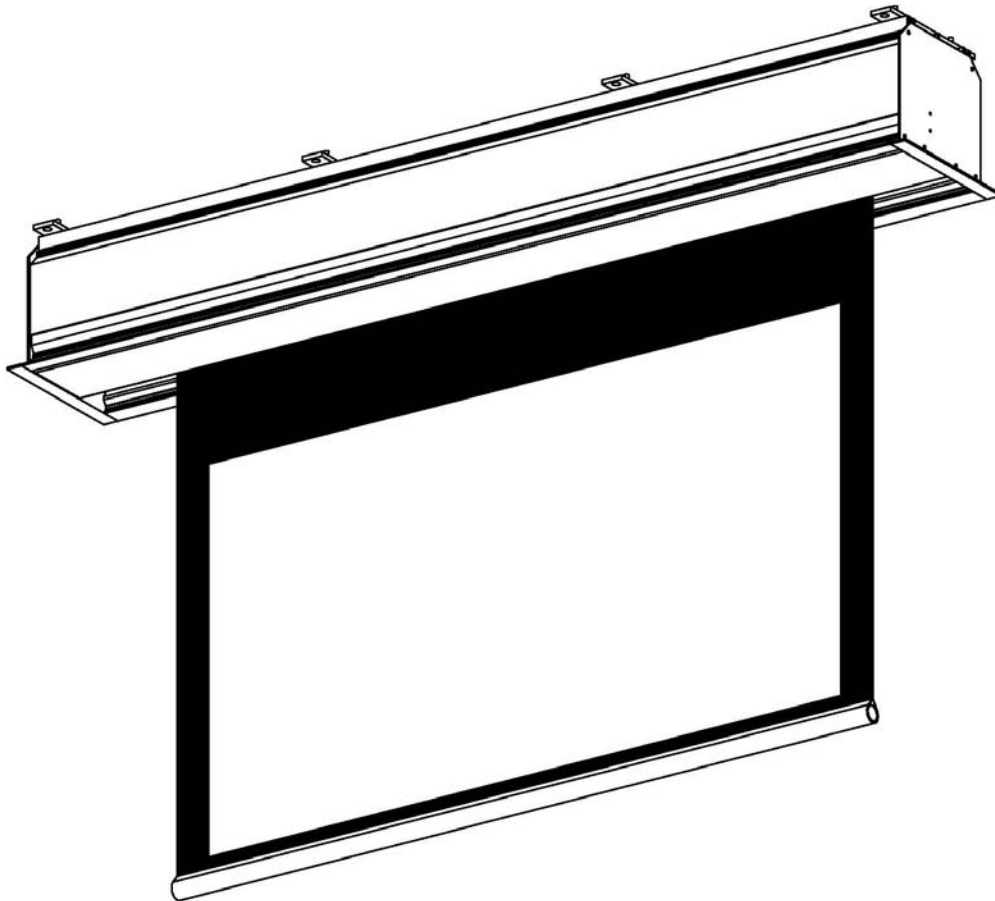


# Installation Instructions

## **Lectric 2-C & 4-C**

FLUSH CEILING MOUNT SCREEN  
LARGE SERIES



VIDEO PROJECTION SCREENS

## IMPORTANT SAFETY INSTRUCTIONS

Basic safety precautions should always be followed; including the following:

- ♣ Read and understand all instructions before proceeding with the installation and operations.
- ♣ Lectric 2-C and Lectric 4-C meet requirement for fire-resistant and low smoke-producing characteristics suitable for operation in a building's environmental air space, such as above suspended ceilings, in accordance with Section 300-22 (C) of the national Electric Code, ANSI/NFPA 70, and sections 2-128, 12-010(3) and 12-100 of the Canadian Electric Code, Part 1, CSAC22.1.
- ♣ Be certain that the supporting structure is sound and capable of carrying the weight as required.
- ♣ Seek qualified electricians to perform electrical requirements.
- ♣ Obtain proper lifting mechanism to raise and hold the unit steady for installation.
- ♣ Plan ahead so the installation can go smoothly and efficiently.



### IMPORTANT WARNINGS AND CAUTIONS!



WARNING: A WARNING ALERTS THE POSSIBILITY OF SERIOUS INJURY OR DEATH IF THE INSTRUCTIONS ARE NOT FOLLOWED.



CAUTION: A CAUTION ALERTS THE POSSIBILITY OF DAMAGE OR DESTRUCTION OF EQUIPMENT IF THE INSTRUCTIONS ARE NOT FOLLOWED.



WARNING: FAILURE TO READ, THOROUGHLY UNDERSTAND, AND FOLLOW ALL INSTRUCTIONS CAN RESULT IN SERIOUS PERSONAL INJURY, DAMAGE TO EQUIPMENT, OR VOIDING OF FACTORY WARRANTY! IT IS THE INSTALLER'S RESPONSIBILITY TO MAKE SURE ALL COMPONENTS ARE PROPERLY ASSEMBLED AND INSTALLED USING THE INSTRUCTIONS PROVIDED.



WARNING: FAILURE TO INSTALL ELECTRICAL REQUIREMENTS ACCORDING TO NATIONAL/LOCAL ELECTRICAL CODES AND REGULATIONS MAY CAUSE PREMATURE FAILURE, FIRE HAZARD, ELECTRICAL SHOCK, UNSAFE PRACTICE AND REVOCATION OF USE.

### ***DISCLAIMER***

Vutec Corporation intends to make this manual accurate and complete. However, Vutec makes no claim that the information contained herein covers all details, conditions or variations, nor does it provide for every possible contingency in connection with the installation for use of this product. The information contained in this document is subject to change without notice. Vutec makes no representation of warranty, expressed or implied, regarding the information contained herein. Vutec assumes no responsibility for accuracy, completeness or sufficiency of the information contained in this document.

### ***PRE- INSTALLATION***

- 1) Carefully cut and remove packing materials.
- 2) Carefully unpack and inspect the unit for sign of damages.
- 3) Be sure to recheck and measure all pertinent dimensions before installation.
- 4) Most basic tools are required for installation.

## SAVE THESE INSTRUCTIONS

VUTEC CORPORATION  
www.vutec.com  
TEL: (954)-545-9006  
FAX: (954)-545-9011  
EMAIL: info@vutec.com

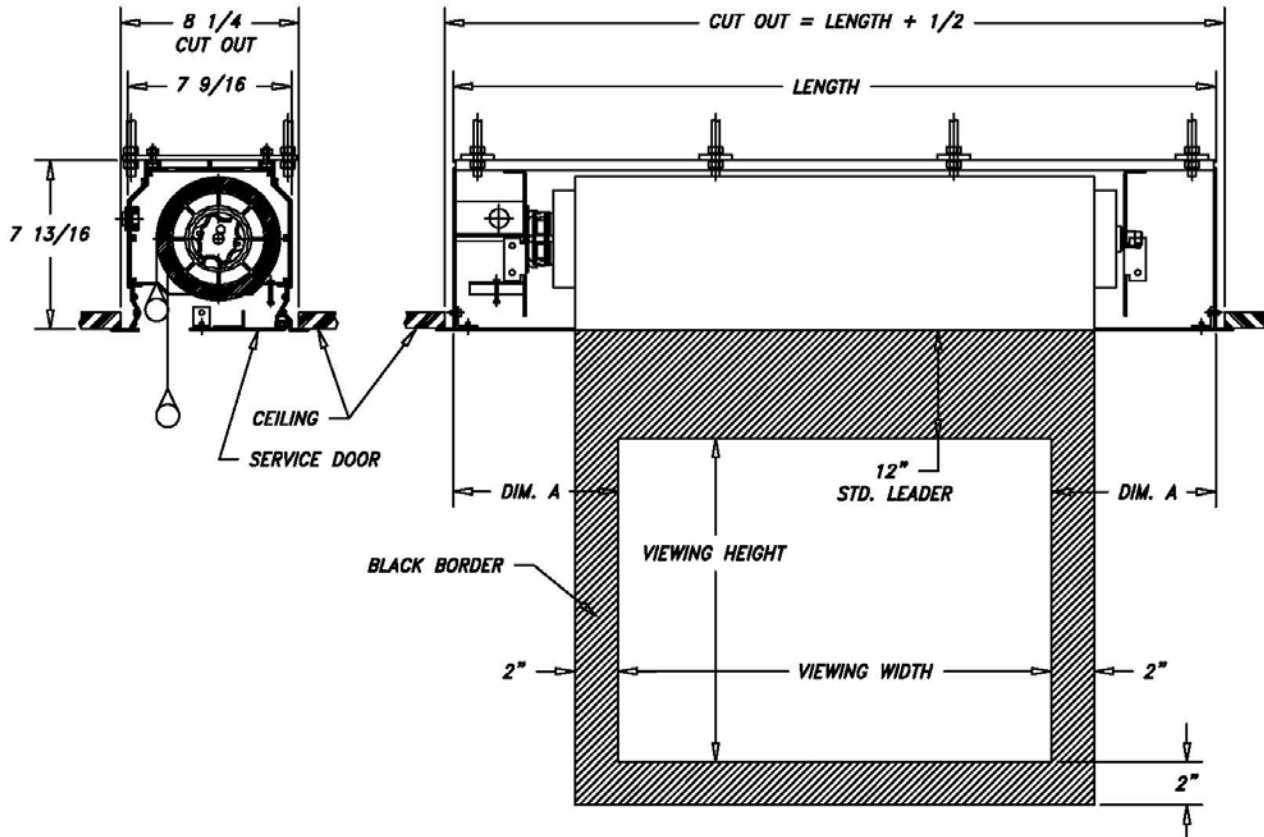


06/26/2017 Rev. B  
INSTL-L2-C\_L4-C-B



# LECTRIC 2-C & 4-C

FLUSH CEILING MOUNT WITH SERVICE DOOR  
 SELF-SUPPORTED (shown) and TAB-TENSIONED screens



**Figure 1**

SCREEN TYPE	LENGTH	DIM. A
SELF-SUPPORTED	VIEWING WIDTH + 15 1/2	7 3/4
TAB-TENSIONED	VIEWING WIDTH + 22 1/2	11 1/4

## **HOUSING INSTALLATION**

Lectric 2-C is designed for flush ceiling mount. As shown in Figure 2a, Option 1 is the preferred mounting method which requires access space above the ceiling. The mounting brackets may be placed anywhere along the housing length as desired. However, it is best to evenly space them for uniform weight distribution. It is recommended the end mounting brackets should not be more than 4 inches from each end of housing.

The housing has a built-in trim flange around the bottom. Ceiling tiles or drywall may be placed on top of this flange for a finished appearance.

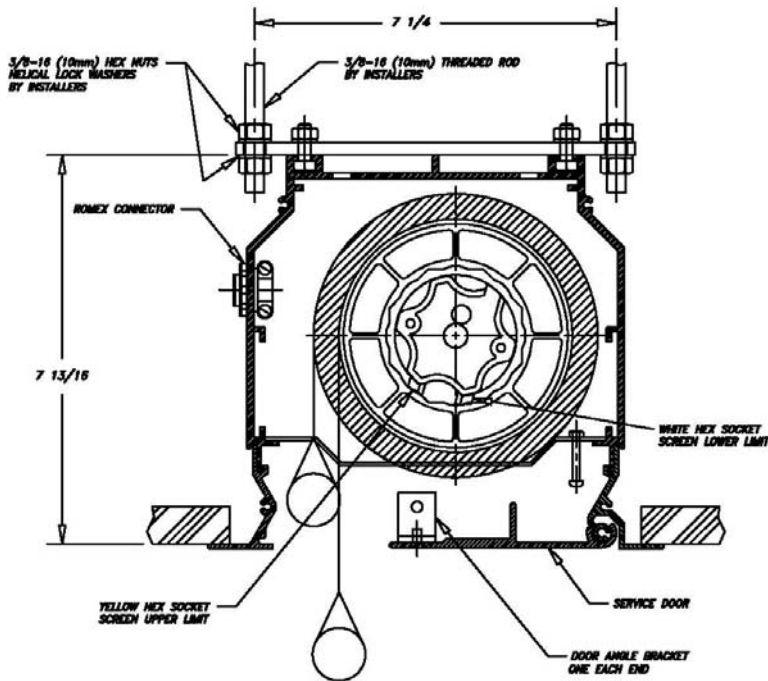


**WARNING: SUPPORTING STRUCTURE MUST BE CAPABLE OF CARRYING 4 TIMES THE UNIT WEIGHT. CHECK WEIGHT DATA AT THE END OF THIS DOCUMENT.**

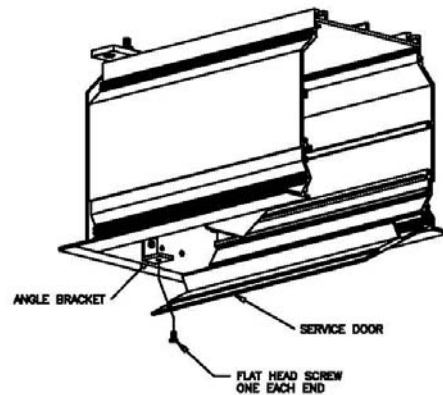
Threaded rods of 3/8 (10mm) diameter, hex nuts and helical lock washers are to be provided by installers.

After securing the housing in the ceiling check that the housing is level and plumb. Make adjustments as necessary then tighten the hex nuts.

*It is recommended that safety cables be added to the housing for additional safety concern. The cables may be looped and tied to end mounting brackets between the housing and bracket (Figure 2c).*



**Figure 2a**  
**Option 1- Suspended mounting**



**Figure 2b**  
**Some Parts Removed  
For Illustration**

An alternate mounting method is available as shown in Figure 3. This mounting option must be requested in advance at the time of order placement for the mounting holes to be drilled.

It is the installer responsibility to supply proper mounting hardware for option 2 mounting.

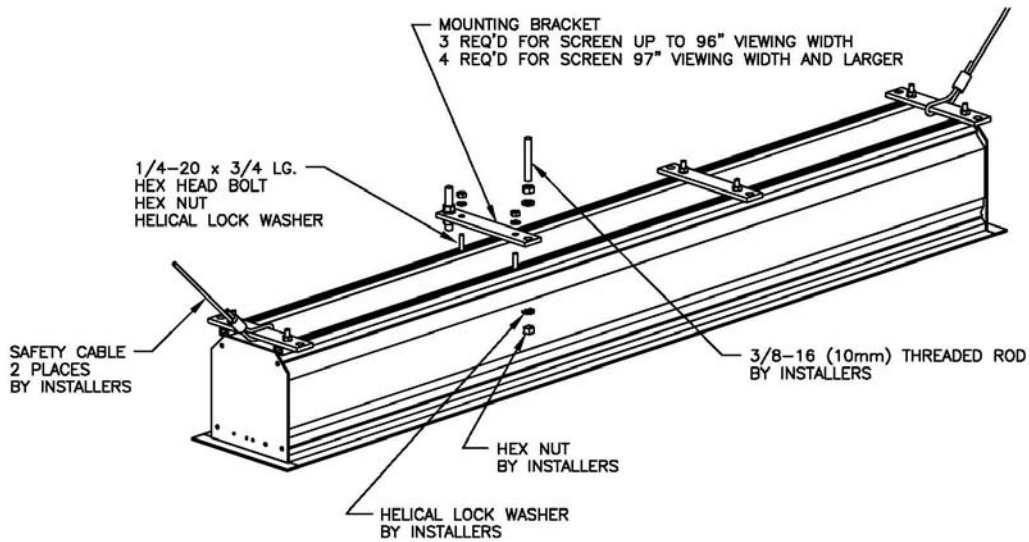
Option 2 mounting requires the screen roller assembly to be removed to gain access for the mounting screws along the middle section of the housing.

Refer to the *SCREEN ROLLER ASSEMBLY REMOVAL* Section for instructions.

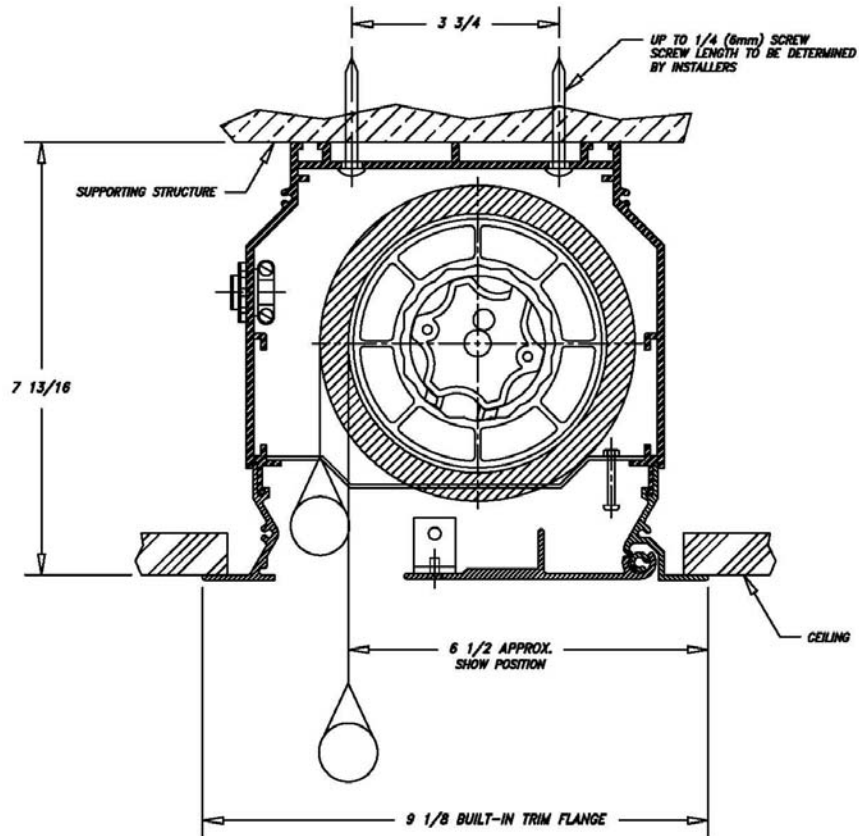


**CAUTION:** BE SURE TO PLACE THE CONNECTING WIRES INSIDE BEFORE PROCEEDING WITH THE HOUSING INSTALLATION.

Install the housing once the screen roller assembly is removed. Be sure the housing is level and plumb.



**Figure 2c**  
**Option 1 - Suspended Mounting**



**Figure 3**  
**Option 2 - Blind Pocket Mounting**

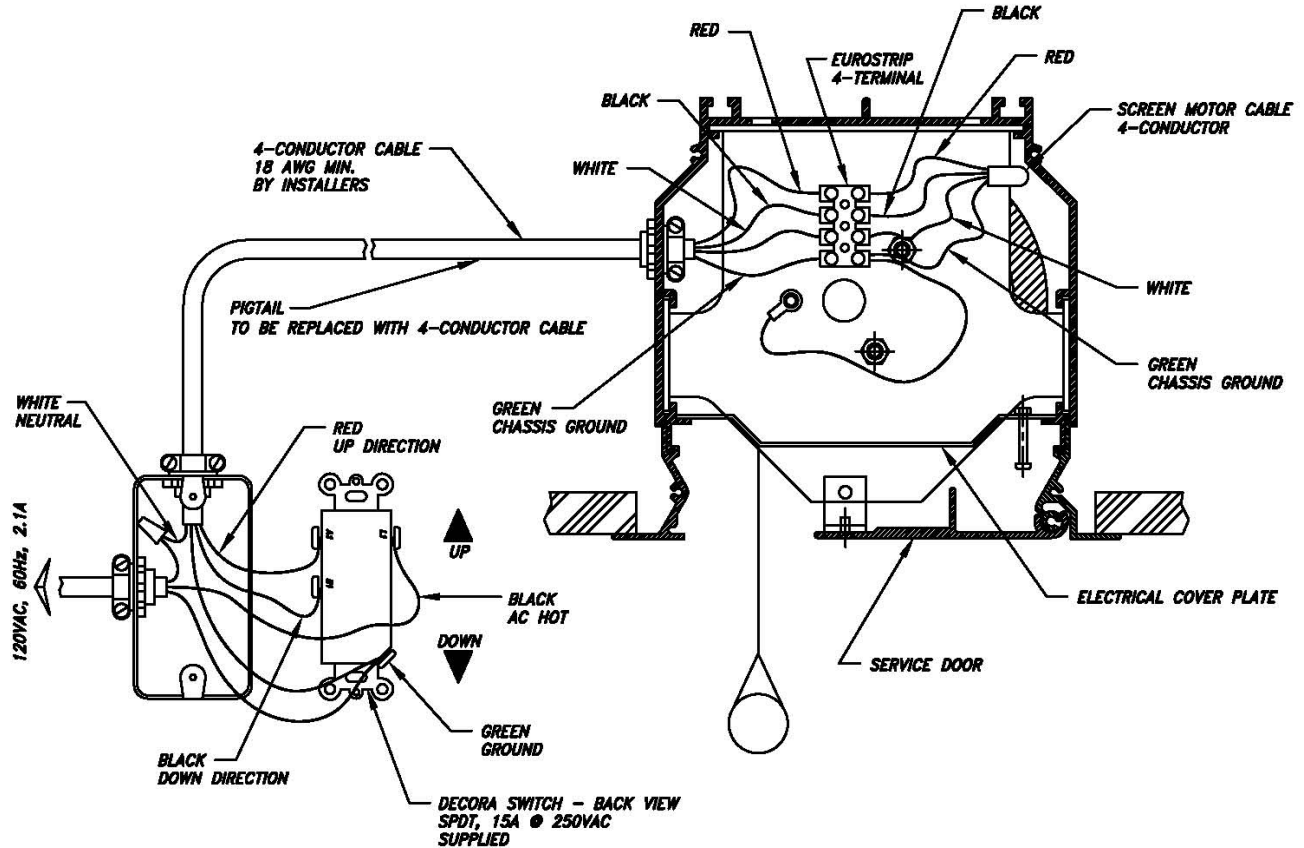
## ELECTRICAL CONNECTIONS

All required wirings are connected. The pigtail (Figure 4a or 4b) should be replaced with a 4-conductor cable (by installers) straight run to the wall switch or other control devices.

Schematics are provided with this instruction at the end.



**WARNING: THE INITIAL HOOK-UP AND CALIBRATION PROCEDURES ARE INTENDED TO BE PERFORMED BY A QUALIFIED SERVICE MAN.**



**Figure 4a**  
**Electrical Connections 120 VAC**

On each end of the service door; remove the screws (Figure 2b) to untie the door.

Remove the electrical cover to gain access to the electrical compartment. Simply push up or using a screwdriver and make a light hit upward on the cover to pop open (Figure 5a).

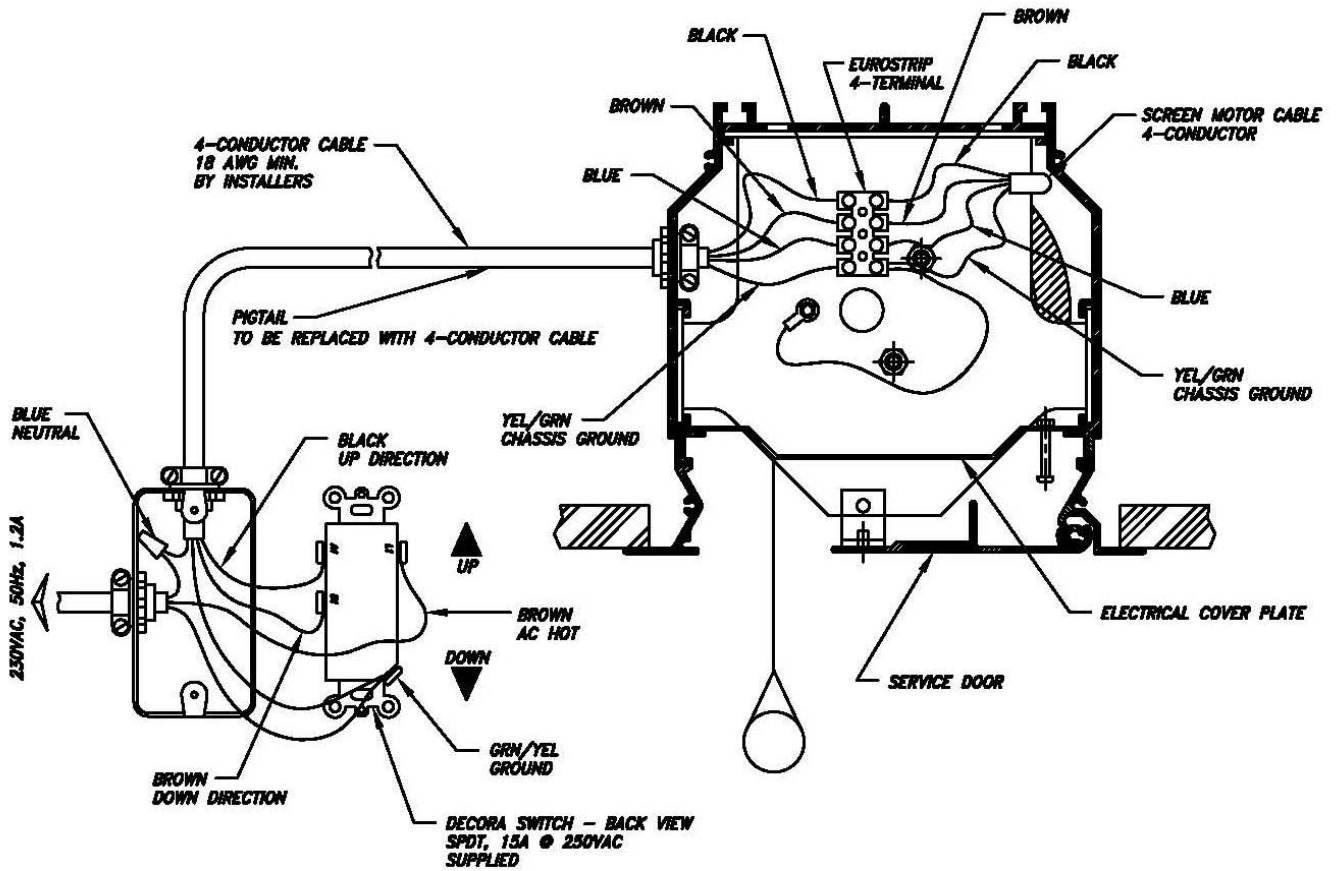
Pull down the Eurostrip to replace the pigtail with 4-conductor cable. The cable should go to location where the wall switch is to be located.

Make connections to the wall switch. Perform quick test by sending the screen down and then up.

Push the Eurostrip back up in the electrical compartment and reinstall the electrical cover. Refer to Figures 5a and 5b, keep the cover in contact with the motor bracket while pulling down on the screw of the cover. Note the cover is lightly force fit inside the housing.

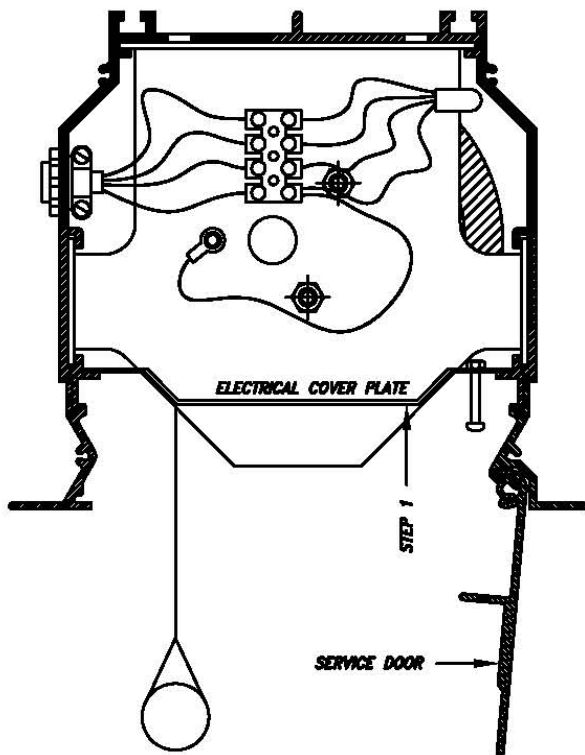
Close the service door and reinstall the screw on each end.

**NOTE: FOR 230VAC INSTALLATION, REFER TO FIGURE 4b.**

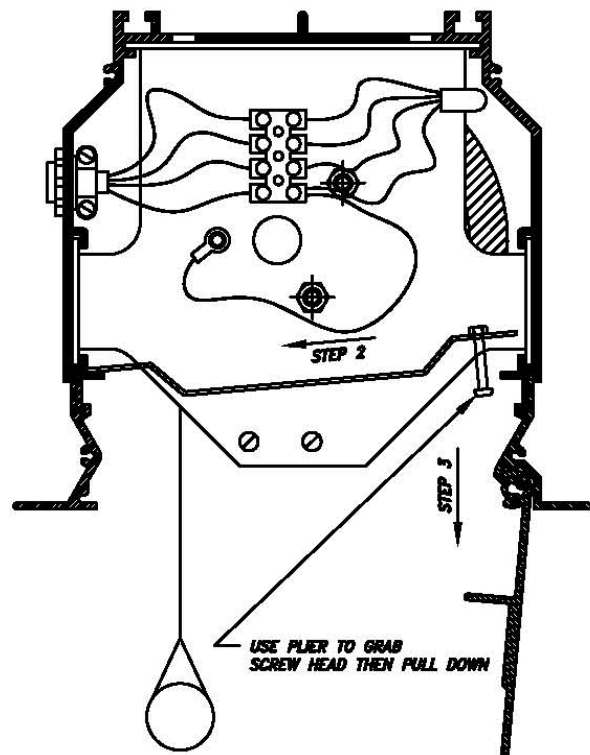


**Figure 4b**  
**Electrical Connections 230 VAC**

The screen may also be operated by optional IR/RF remote control, optional 12VDC trigger relay, optional Low Voltage control or optional Home Automation control by AMX, Crestron, etc. Consult Vutec for further details.



**Figure 5a**



**Figure 5b**

### **UPPER LIMIT ADJUSTMENT**

The upper limit for the screen is when the bottom weight bar stop just inside the housing. Do not change the screen upper limit unless absolutely necessary.

### **LOWER LIMIT ADJUSTMENT**



**WARNING:** UNLESS OTHERWISE SPECIFIED AND ORDERED, STANDARD LEADER DROP IS 12 INCHES MAXIMUM. EXCEEDING THE MAXIMUM MAY CAUSE THE SCREEN TO FALL OFF THE ROLLER AND VOID THE WARRANTY.

#### HEX SOCKET LIMIT SWITCH

Key features of the hex socket (Figures 2a and 6) limit switch:

- ⇒ Each full turn (360 degrees) of the hex socket cause the screen to travel approximately 3/4 inch.
- ⇒ Follow the label affixed to the electrical cover plate for turning of the hex sockets.
- ⇒ As the hex socket is turning, the screen will move only in the direction of increasing travel.  
*Hint: Going down direction (lower limit) will see the screen move as more down being adjusted but not the opposite.*

#### MORE SCREEN DROP

Send the screen down to the lower limit and it should stop automatically. Leave the control switch on. Turn the White hex socket in the + direction (see label on electrical cover plate) to make the screen come down more. Stop turning when the screen reaches the desired lower limit.



### LESS SCREEN DROP

Send the screen down to the lower limit and it should stop automatically. Leave the control switch on.

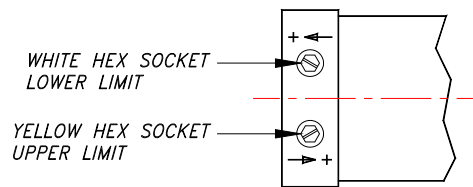
Determine the number of turns required to stop the screen above the desired lower limit.

Turn the White hex socket in the - direction the number of turns that has been determined to make it stop above the desired lower limit.

Send the screen up half way and stop. Send it down and expect it to stop above the desired lower limit.

Repeat until the screen has stopped above the desired lower limit.

When the screen stops above the desired lower limit; proceed to **MORE SCREEN DROP** part to lower the screen to the desired lower limit.



USE 5/32 (4mm) HEX KEY TO TURN  
OR SMALL FLAT BLADE SCREWDRIVER

**Figure 6**  
**Limit Switch Sockets**

### PUSH BUTTON LIMIT SWITCH

Depending on availability, some screens might be equipped with motor with push button limit switches.

Key features of the push button limit switch:

- ⇒ Button popped out; free running - motor limit switch is not engaged.
- ⇒ Button pushed in; motor limit switch is engaged.
- ⇒ Yellow button for upper limit. White button for lower limit.

### CHANGING THE UPPER OR LOWER LIMIT

Changing the upper or lower limit of the motor with push buttons is simple.

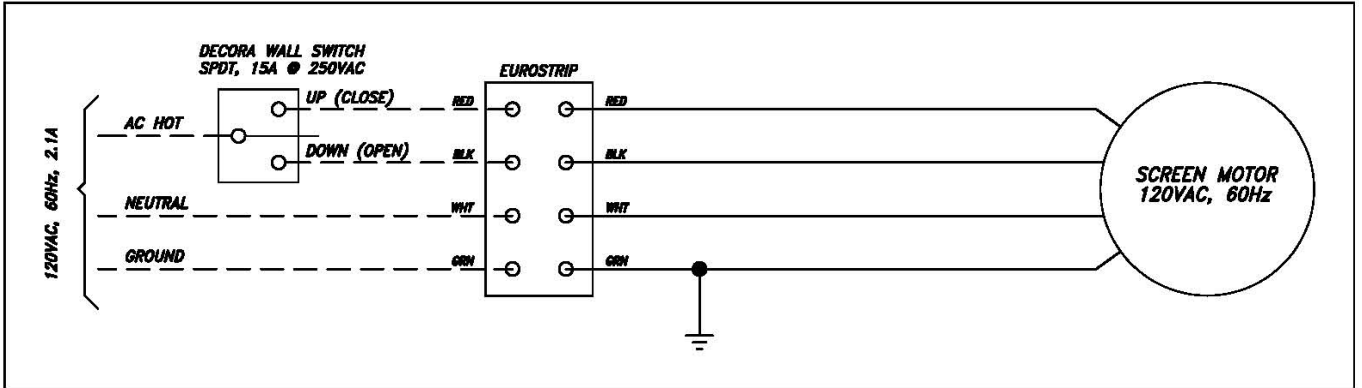
Disengage the limit for the up or down by popping out the appropriate yellow or white button.

Send the screen to the desired limit then stop.

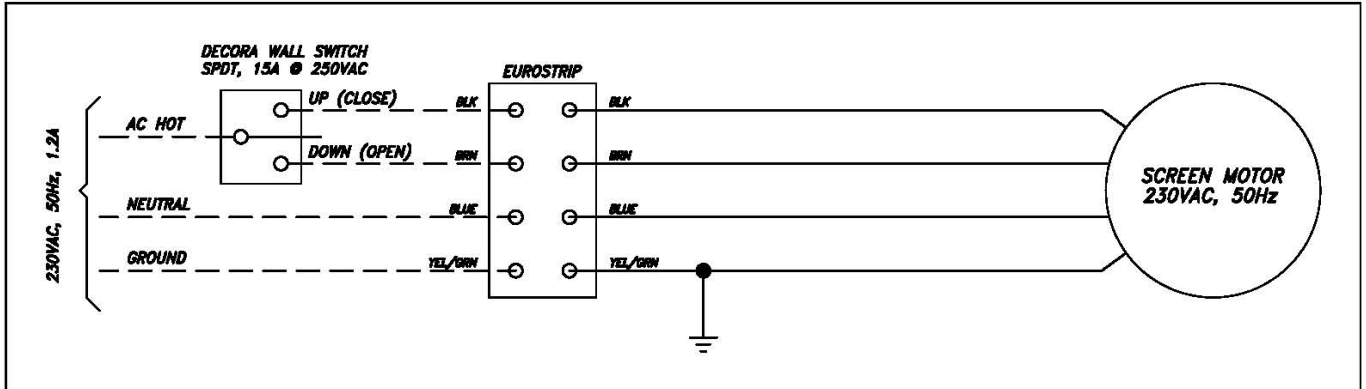
Push in the button to engage the limit switch. The screen limit is set.

Test run the screen and checks the desired limit. Repeat as often.

**SCHEMATIC**



**120 VAC Installations**



**230 VAC Installations**

## TROUBLESHOOTING

SYMPTOM	CAUSE	SOLUTION
Door remains closed and screen will not come down.  <b>Motor does not hum.</b>         <b>Motor hums.</b>	a- Check breaker fuse. b- Check wall switch. c- Push button limit switches might be tripped.  d- Thermal overload tripped. e- Defective motor or wall switch. f- Temporary binding. g- Capacitor burned out.	a- Replace blown fuse. b- Check wall switch connections. Bypassing wall switch as a test. c- Manually open trap door. See Electrical to reset push button limit switch. Reset Yellow button for lower limit. d- Let motor cool down for 15 minutes. e- Replace motor or wall switch. f- Manually open trap door check for binding. g- Replace motor.
Screen will not go up.  <b>Motor does not hum.</b>         <b>Motor hums.</b>	a- Check breaker fuse. b- Check wall switch. c- Push button limit switches might be tripped.  d- Thermal overload tripped. e- Defective motor or wall switch. f- Temporary binding. g- Capacitor burned out.	a- Replace blown fuse. b- Check wall switch connections. Bypassing wall switch as a test. c- See Electrical to reset push button limit switch. Reset White button for upper limit. d- Let motor cool down for 15 minutes. e- Replace motor or wall switch. f- Check for binding of roller assembly. g- Replace motor.
Coasting.	a- Defective brake.	a- Replace motor.
Trap door closed and motor hums. Trap door not quite closed but motor stop.	a- Check Door Close Limit (DCL) switch	a- Adjust DCL switch by moving it up or down.
Noisy operations.	a- Cyclic noise (squeaky) pattern.  b- Gear noise	a- Lubricate roller shaft and bearing at Idler bracket with typical oil.  b- Replace motor.

## ACCESSORIES INCLUDED

- 1 **SPDT DECORA SWITCH**
- 1 **SWITCH COVER PLATE**
- 4 **MOUNTING BRACKET**
- 9 **1/4-20 X 1" LONG HEX HEAD BOLT**
- 9 **HELICAL LOCK WASHER FOR 1/4 BOLT**
- 9 **1/4-20 HEX NUT**